

# Einar Sound VC-01i Measured Performance

## Full Balanced Topology:

### Input Buffer and Amplifying Circuits (for ONE channel):

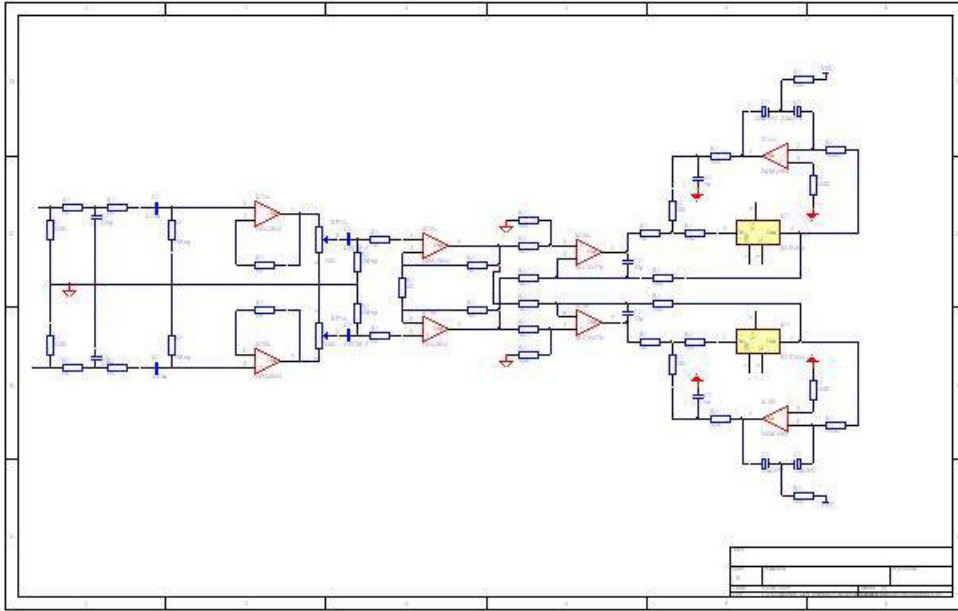

### Output Buffer Circuit (for one channel):

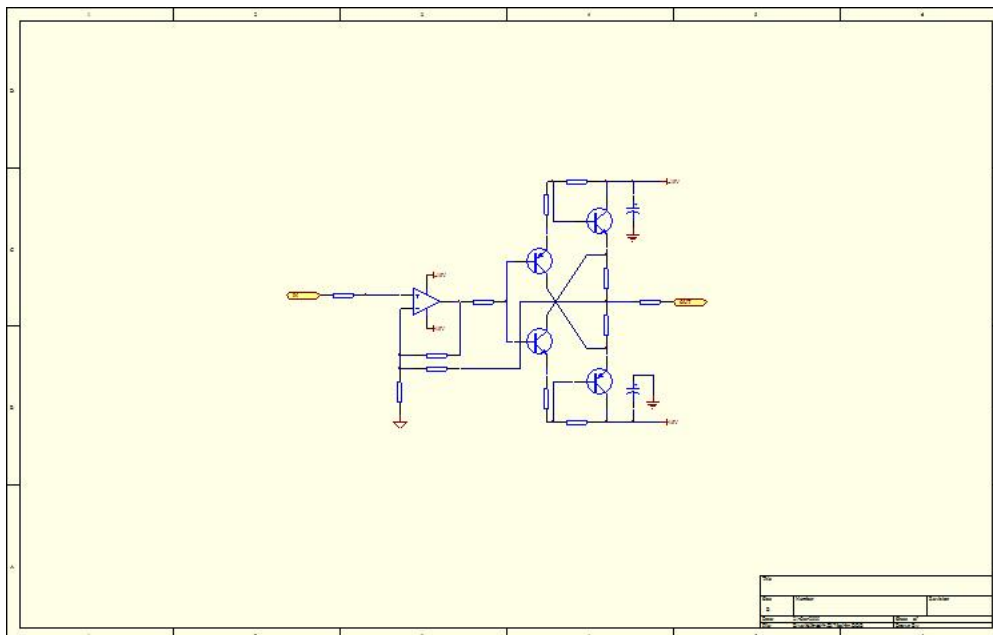

# Measurements: (Balanced input and output)

Testing instrument: Audio Precision SYSTEM 2722

